

INSTRUCTION MANUAL FOR DRILLGRINDER BSM20 AND SZ



Original manual
Please keep for further use!

CONTENT

EC-Declaration of conformity	3
Description of product	4
Description of function	5
Basic equipment / Accessory BSM 20 / SZ	5
Technical data BSM 20 / SZ	6
General safety advice	7
Description of safety symbols	8
Basic safety operations	9
Request to the operating personal	10
Special kind of danger	10
Set up / Transport / Hints for disposal of packing material	11
Start up / Checks before first start up	12
Operation BSM 20	
Description of parts	13
Grinding of right hand drills	14
Grinding of left hand drills	15
Web thinning	17
Thinning Split-Point	18
Four facet shape / cutters	19
Grinding of stepped drills	20
Grinding of carbide drills (Widia) - drills	21
Grinding of sheet metal drills	22
Grinding of wood drills	23
Grinding of Forstner drills	24
Grinding of the outer cutting edges	25
Countersink sharpening device SVR 20	26
Alignment of the sharpening device SVR 20	27
Montage + dressing the grinding wheel before first operation / adjustment of the grinding wheel protection	28
Change the grinding wheel	29
Dressing of grinding wheel	30
User manual SZ	31
Operating part (On/Off switch)	32
Description of the machine	33
Description of the machine / wheel dressing	34
Operation of the SZ	35
Maintenance / Wear parts BSM 20 / SZ / Repairs	36
Warranty / Disposal of the machine	37
Spare part lists BSM 20 / SZ	38

EC DECLARATION OF CONFORMITY

The manufacturer:

Kaindl-Schleiftechnik
Reiling GmbH
Remchinger Straße 4

75203 Königsbach-Stein
Germany

Herewith declares tht the machine
decribed hereafter:

Grinding machine
Typ: **BSM 20 + SZ**

Refers to the security and health requirement of
the following EC instructions:

EC-Machine instruction (2006/42/EC)
EC-instruction EMV (2004/108/EC)

Applied harmonised norms:

**EN ISO 12100; EN ISO 13857; EN ISO 13732-1;
EN 60204 Part 1; EN 61000-6-1; EN 61000-6-2;
EN 61000-6-3; EN 61000-6-4**

**Changes in engineering design, having effect on technical data stated in this
operation manual and directed use, therefore change the character of the machine
substantially make this declaration of conformity invalid!**

These documents had been made up by:

Reinhard Reiling

Kaindl-Schleiftechnik
Reiling GmbH
Remchinger Straße 4
75203 Königsbach-Stein

Königsbach-Stein dated 29.12.2009

.....
Reinhard Reiling, General manager

1. DESCRIPTION OF PRODUCT

1.1 DIRECTED USE

The **drill grinding machine BSM / SZ** is exclusively determined for occasional grinding of spiral-, step-, wood- and Forstner drills as well as sheet metal-, stone-, (carbide) drills, turning tools and countersinks.

For other use than listed here, the machine is not designed for and is regarded as a matter of adverse use!

The directed use includes also reading this operation manual, as well as keeping all containing directions of use - especially the safety information.

In case the drill grinding machine BSM 20 / SZ is not used as per the intended purpose, a save operation cannot be granted.

For all personal- and material damages, arising by not intended use, not the manufacturer, but the user of the Kaindl BSM 20 / SZ is responsible!

1.2 PREDICTABLE WRONG APPLICATION

The use as a table machine for manually guided grinding of workpieces, such as chisel, sheet metal, screwdriver, etc. is not allowed!

2. DESCRIPTION OF FUNCTION

This mobile drill grinding machine made by Kaindl is unique as to its design and offers a genuine alternative to bigger and considerably more costly equipments. Owing its solid construction, its high precision, its small space requirement and its favourable price, the Kaindl grinding machine is an indispensable auxiliary equipment and a real measure of economy even for single operation sections and for smaller workshops. The machine facilitates the adjustment and the resharpener of twist drills to that extend, that everybody will be able to resharpen drills with every lib angle that is imaginable. Form the prism reversing process results automatically the highest precision and cutting egde symmetry. The well planned conception and the possibility of an easy change of all party subject to wear, preserve the Kaindl drill grinding machine as an indispensable aid in your work-shop. Even after many years of employment.

2.1 BASIC EQUIPMENT BSM 20 / SZ

BSM 20: Range 1 - 20 mm (prism), complete with CBN-grinding wheel and optical lens LED lighted.

SZ: with corundum cup wheel and grinding table with electro magnet, diamond cup wheel, diamond dresser and optical lens LED lighted.

3. ACCESSORY AND SPARE PARTS BSM 20 / SZ

- 17073 CBN grinding wheel \varnothing 125 mm grit B126/3, covered on 3 sides, width 20 mm
- 16490 CBN grinding wheel \varnothing 125 mm grit B76/3, covered on 3 sides, width 20 mm (standard)
- 17556 CBN grinding wheel \varnothing 125 mm grit B46/3, covered on 3 sides, width 20 mm
- 10895 Corundum grinding wheel 125 x 20 x 20 grit 60 (coarse)
- 10890 Corundum grinding wheel 125 x 20 x 20 grit 80 (standard)
- 10891 Corundum grinding wheel 125 x 20 x 20 grit 180 (very fine)
- 10893 Corundum grinding wheel 125 x 05 x 20 grit 100 (HSS wood bits)
- 10896 Corundum cup wheel grit 60 (standard) for SZ
- 10897 Corundum cup wheel grit 80 (medium) for SZ
- 10898 Corundum cup wheel grit 100 (fine) for SZ
- 15422 Grinding wheel support
- 14581 Diamond grinding wheel D 76, covered on 3 sides for carbide wood drills
- 14580 Diamond grinding wheel D 76, covered on 3 sides for carbide drills
- 11223 Diamond cup wheel D 126 (standard) for SZ
- 10887 Diamond cup wheel D 76 (fine) for SZ
- 10906 Universal clamping device for single-lip cutters, cut off tools, etc. for SZ
- 10889 Magnetic depth stop for cutters
- 10875 Countersink sharpening device SVR 20 with collet 10 mm
- 10877 Collet 6 mm for SVR 20
- 10878 Collet 8 mm for SVR 20
- 10879 Collet 12 mm for SVR 20
- 10901 Morse taper sleeve MK1
- 10902 Morse taper sleeve MK2

4. TECHNICAL DATA

BSM 20 and SZ with magnetic table

Dimension drill grinding machine BSM 20:

L x D x H 370 x 350 x 270 mm
Weight 22 Kg

Dimension SZ :

L x D x H 500 x 420 x 310 mm
Weight 40 Kg

Movement Drill grinding machine:

Prism clamping range 1 - 20 mm
Motor feed max. 65 mm
Prism feed max. 45 mm
Clearance angle stepless adjustable
Top angle stepless adjustable from 60°-200°
Grandient of spindles 3 mm (1 scale line = 0,03 mm)
Grinding wheel Corundum grinding wheel 125 x 20 x 20 grit 80,
Hardness M, Vmax = 35 m/s ; n = 5400 RPM
Noise emission < 70 dB(A); Emission- acoustic pressure at workplaces
(ear level) as per DIN EN ISO 11204
Operation condition Sharpening of a HSS 15 mm dia drill
Run out time of grinding wheel approx. 10 seconds

Grinding table

Movement 305 mm
Table size 170 x 100 mm
Swing range table stepless +20° to -60°
Grinding wheel Corundum cup wheel 125/105 x 40 x 20 grit 60,
Hartness J, Vmax = 30 m/s ; n = 4600 RPM
Noise emission < 70 dB(A); Emission- acoustic pressure at workplaces
(ear level) as per DIN EN ISO 11204

Electrical connection:

Total value 230 Volt / 50 Hz / 130 Watt / 2800 U/min
Degree of protection IP 54

Technical changes may be done without notification!

5. GENERAL SAFETY ADVISE

5.1 DUTY OF TAKING CARE BY THE USER

The drill grinding machine BSM 20 / SZ has been designed and constructed under consideration of an endangering analysis and careful selection of observed harmonized norms, as well as further specifications.

The BSM 20 / SZ meets the state of the art and grants a maximum of safety.

This safety can only be achieved in daily work, when all necessary steps are taken. It is the duty of taking care by the user to plan and control these steps.

The user especially has to take care that:

- the BSM 20 / SZ is used as directed (see chapter "description")
- the machine is used in flawless workable condition, especially that the safety installations are checked
- requested personal security equipment for the operator is available and used
- the operation manual is always in a readable condition, complete and available near the machine BSM 20 / SZ
- the drill grinding machine BSM 20 / SZ operated only by personnel that knows the contained operating instructions and the safety information
- Carrier active implants (pacemakers) must meet the safety distance of 20 cm between the magnetic table of the sharpening center SZ and the position of the implant
- all safety and warning instructions are not removed from the machine and kept readable

Persons having not familiarized with the security advises, described herein, can't operate the machine.

6. DESCRIPTION OF SAFETY SYMBOLS

In this instruction manual, the following safety symbols are used.

These symbols shall attract the readers attention to the text next to the symbols.

These symbols indicate that there is an existing danger to live and health of persons.



Protect eyes while grinding, against kicked around particles



General danger



Before changing the grinding wheel or moving disconnect from electric current

The lens cover of the magnifying lamp has to be closed after use :

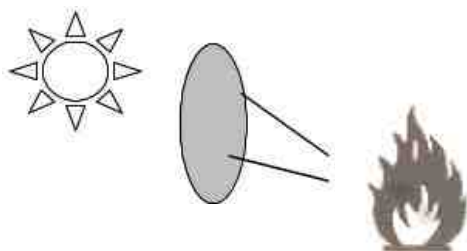

Caution:

Lens cover always must be kept close when not in use (danger of fire by sunbeam)

7. BASIC SAFETY OPERATIONS

Keep information on-hand:

This instruction manual has to be kept beneath the machine. It has to be granted, that all persons working on the machine have access to the instruction manual. Additionally there should be provided special advises in sence of a safe workplace.

All safety and operation labels on the machine should be keep in good condition and readable. Damaged or non readable labels have to be replace immendiatly.

These symbols indicate that there is an existing danger to live and health of persons.



For all grinding works with BSM 20 / SZ always wear safety glasses. Grinding dust may hurt your eyes.



Only remove the grinding wheel protection for changing the wheel. Never operate the machine with complete grinding wheel protection.



Before changing the grinding wheel or moving, disconnect from electric current!

8. REQUEST TO THE OPERATING PERSONAL

Only persons who are familiar with this manual are allowed to work with this machine.

9. SPECIAL KIND OF DANGER

Before starting the machine, the following jobs have to be done:

- Check the machine for visible damage and eliminate ascertainend defects.
- The operation of the machine is only permitted in flawless condition.
- Electrical connections have to be checked regularly.
- Fix loose connection.
- Damgages electric cables have to be immediately replaced an electrician.
- Never clean electric parts with water or simmilar liquids.

Changes on the machine:

Due to safety reasons changes on the machine without permission are nor allowed. Only use original - spareparty, - original wear parts original accessories. These parts are ecpecially designed for this machine.

10. SET UP

Environmental conditions for set up

Use the drill grinding machine / Tool sharpening center only in dry rooms.
Environmental temperature from +5 to +50°C.

Humidity: up to 90%, not condensing

The BSM 20 / SZ is a table version.

Pay attention that the machine has a safe stand on the work table.

The place has to grant a vibration free running on the machine.

10.1 TRANSPORT

The machine is delivered in a box on a pallet (approx. 50 Kg).

The machine has to be lifted outside diagonal, BSM 20 approx. 25 Kg; SZ approx. 40 Kg

Remove transport locks (only for SZ)

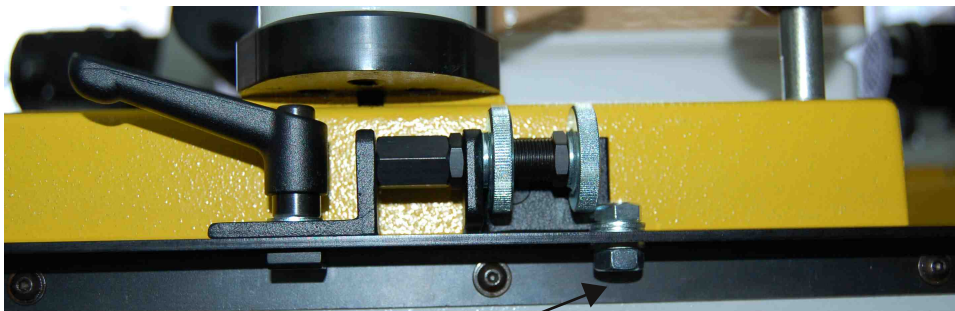

Transport locks

After you have unpacked and placed the machine on a work table, please remove the transport locks. (see picture)

11. HINTS FOR DISPOSAL OF PACKING MATERIAL



The carton can be recycled and is for paper waste.
The rest of the packing is for non recycling waste.

12. START UP

In order to prevent damage to the machine or injuries, please pay attention to the following items before starting:

- Check that all tools or part not belonging to the machine have been removed before starting.
- Sound test, assembly and removal of the grinding wheel (see page 28)
- Also read the chapter "General safety advise".
- Wear protective glasses.

12.1 CHECKS BEFORE FIRST START UP

- Check electric components for damage (sight check).
- Check guidance for soft turning.
- Check fixed parts.

13. DESCRIPTION OF PARTS

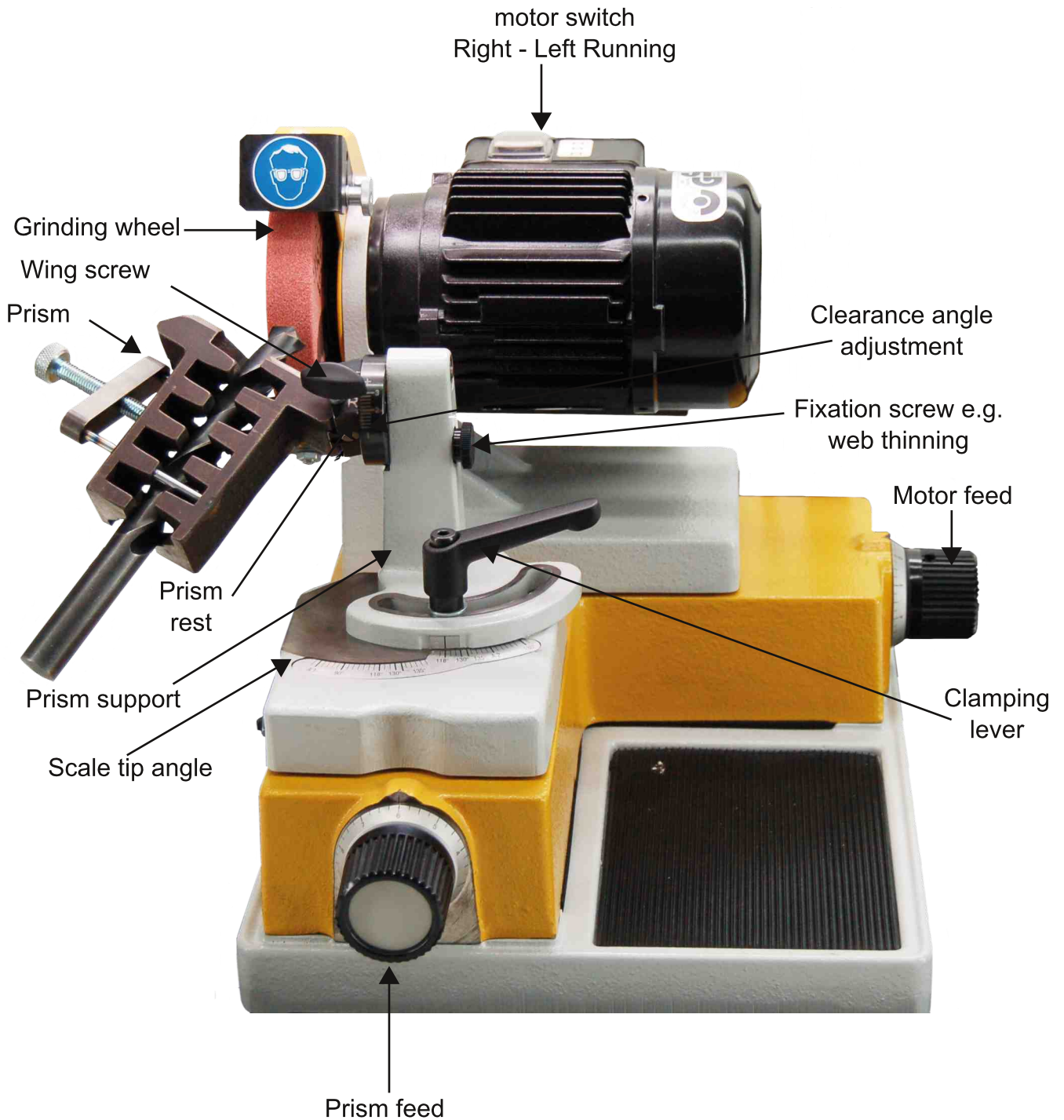

14. GRINDING OF RIGHT HAND DRILLS

Alignment of drill:

The reversing prism has a clamping range from **2-20 mm**. Open the prism by turning the knurled screw. Place the drill in the prism.



Let project the drill around approx. **20-25 mm** outside the prism clamp. Close the prism carefully with the knurled screw, pay attention the the drill still can still be turned. Align one cutting edge between both graduation lines (see picture). Now tighten the prism with the knurled screw by hand (without use of force). The drill is know aligned and ready to sharpen.

Slide prism with the drill onto the prism support and fix with the wing screw. Adjust the requested top angle (standard **118°**) on the prism support an fix with the clamping lever.

- right part-scale: support to right stop dog (slot) and adjust clearance angle.
- left part-scale: support to left stop dog (slot) and adjust clearance angle.

It does not matter which part-scale you use. The clearance angle is adjusted by the scale for the clearance angle.

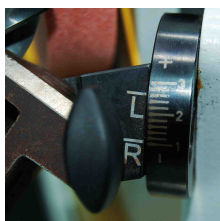

- **Direction 3** = more clearance angle
- **Direction 1** = less clearance angle

The clearance angle is adjusted by the clearance angle scale.

15. GRINDING OF THE DRILL

Move the drill to the front side of the grinding wheel, by using the prism feed and the motor feed. By carefully feeding with the prism feed and meantime turning the prism upside down, grind the first cutting edge completely. Note the graduation No. on the scale, feed back, remove and turn the prism, place again in the prism support, fix it and grind the second cutting edge to the same graduation as noted.

15.1 GRINDING OF LEFT HAND DRILLS

Grinding wheel: depending on sort of drill: use corundum and diamon wheel.

Adjustment on the machine.

Tip angle: 118°

For grinding of left hand drills, the prism rest an clearance angle adjustment hast to be changed (Picture A).

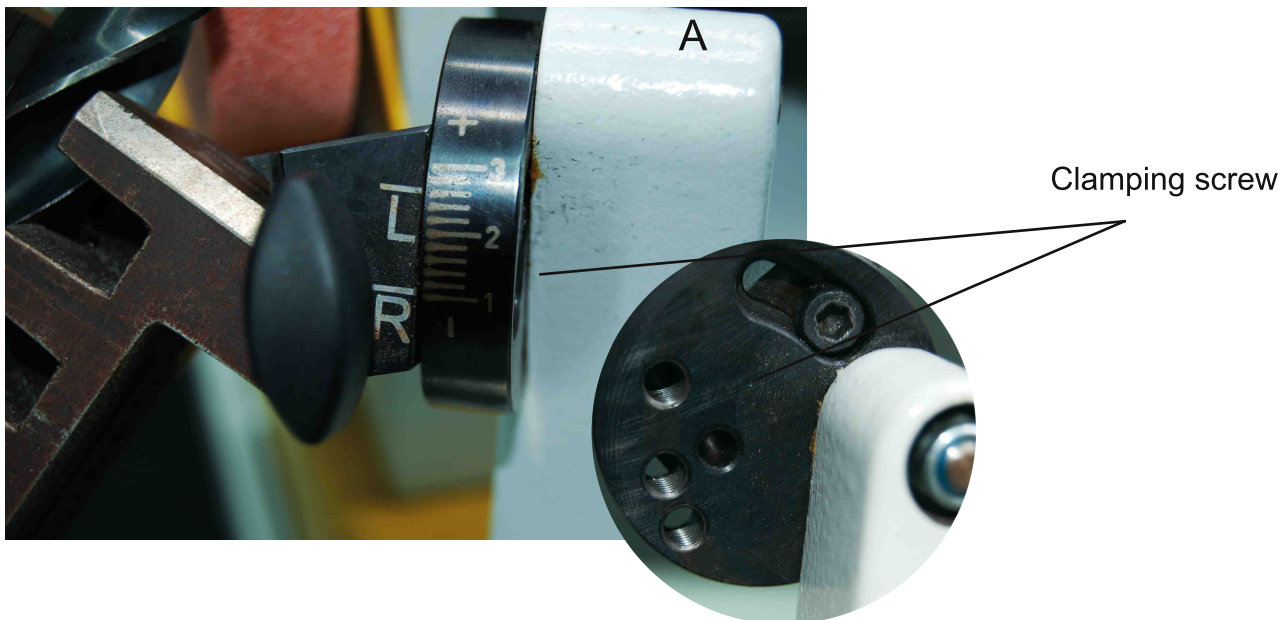

Remove the prism support from the clearance angle adjustment and screw together on the provided fixation thread (L) for left hand drills (Picture B).

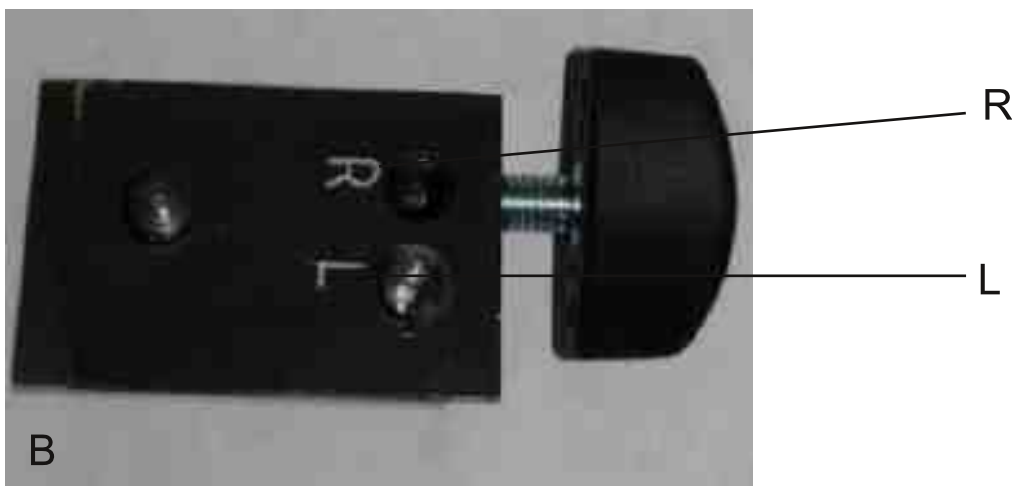

Let project the drill approx. **15 mm** out of the prism.
Align one cutting edge parallel to the graduation mark for left hand drills (Picture).

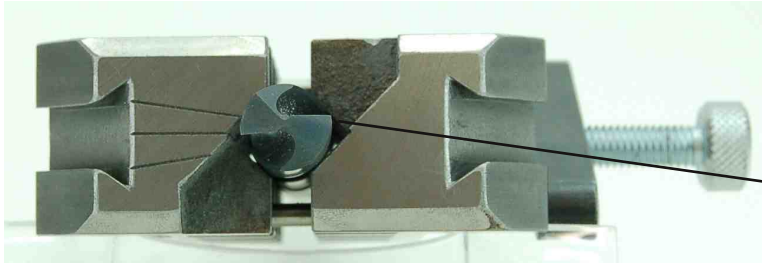

Graduation line for left hand drills

Adjust the request clearance angle on the scale (Picture).
Applicative scale range for left hand grinding: 2-3.
2 = slight clearance angle
3 = high clearance angle

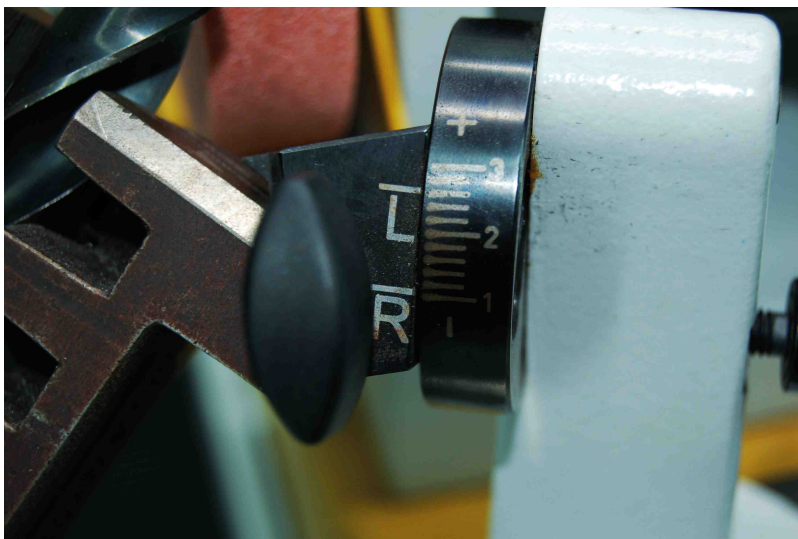

GRINDING OF THE DRILL

Move the drill to the front side of the grinding wheel, by using the prism feed and the motor feed. By carefully feeding with the prism feed and meantime turning the prism upside down, grind the first cutting edge completely. Note the graduation No. on the scale, feed back, remove and turn the prism, place again in the prism support, fix it and grind the second cutting edge to the same graduation as noted.

15.2 WEB THINNING OF DRILLS

Keep the prism support, as described before. Turn the clearance angle adjustment to 1 (see picture below). Fix the turning mechanism in hole **C** of the fixation plate (see picture below). Shift the complete prism trestle to the left stop, adjust on mark **A1**.

By using the motor- and prism feed, grind inside the drill behind the drill cutting edge. Note the graduation No. on the prism feed scale and go back for **3 complete** turns. Do not change the position of the motor feed. Open the clamping lever, reverse the prism, fix again and thin the web of the other side.

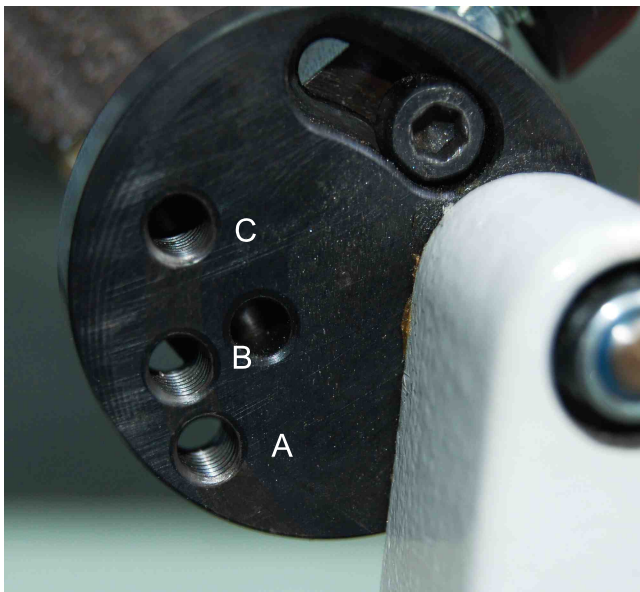

Lock points

A: Lock point for cutter, carbide drill. crossfacet shape, four surface shape

B: Lock point for back or free sharpening

C: Lock point for web thinning

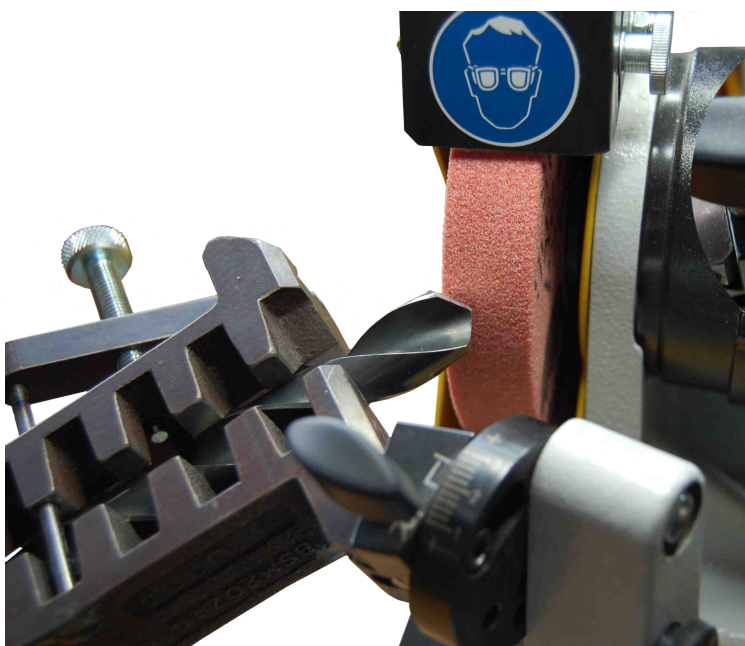

Clearance angle to max minus

Prism rest to Pos. **A1**



15.3 WEB THINNING SPLIT - POINT

After sharpening, do not change the position of drill in the prism. Place clearance angle to position **2** (see picture 1). Fix the swivel mechanism in boring **C** (see picture 2). Place the tip angle to **A2** (see picture 3).

In combination of prism feed and motor feed, sharpen the first side of the drill on-hook (see picture 4). Note the graduation mark of the motor feed and then move back to the left away from grinding wheel. Turn the prism for **180°** and move forward to the same graduation mark as before. The drill should look like on the picture above.

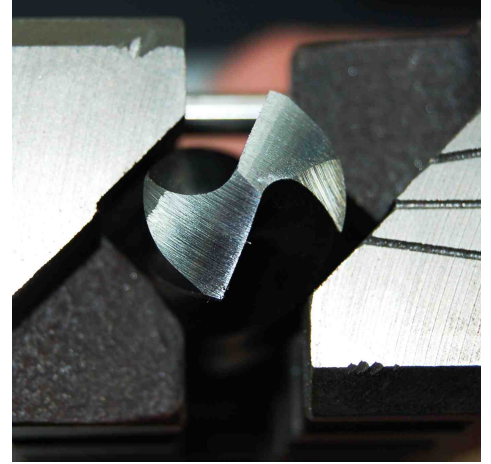

Picture 1

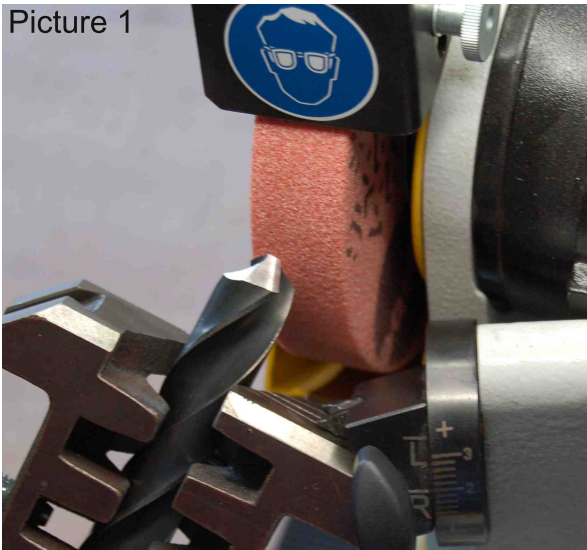

Picture 2

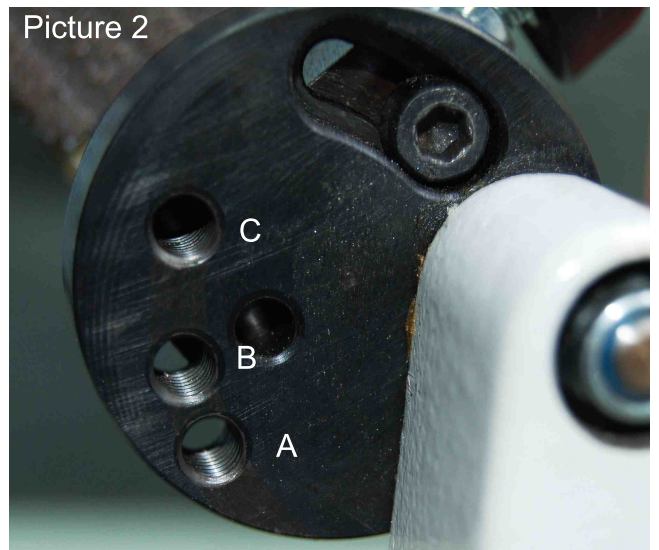

Picture 3



Picture 4

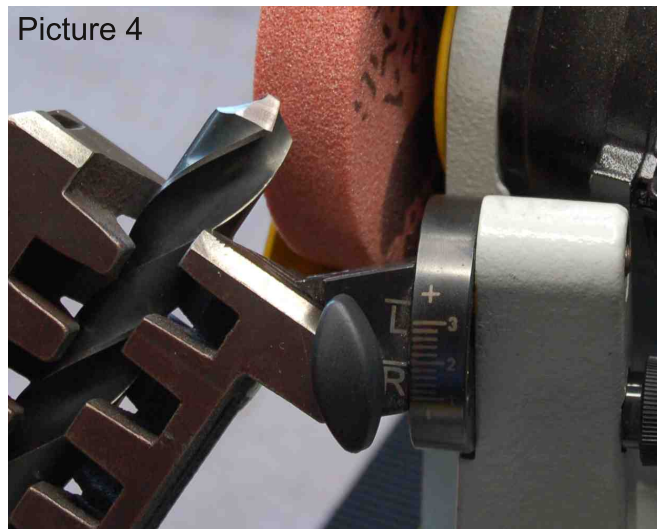

16. GRINDING OF CROSS CUTTING OR 4 FACET DRILLS

Depending of the drill is made of, use the corresponding grinding wheel.

Align one cutting edge parallel to both graduation lines (see picture). Project the drill **approx. 20 mm outside** the prism. Fix the turning mechanism in hole **A** (see picture below).

Adjust the top and clearance angle to your specifications. Grind the first side over the right edge of the grinding wheel by feeding the prism and moving with the motor feed. The second side is ground with the same adjustments. For grinding the back, fix the turning mechanism in hole **B**. The grinding operation is the same as for the first two cutting edges.



16.1 GRINDING OF A CUTTER



Align the cutter to the straight line of the prism

Cutter grinding is slightly different to cross facet grinding. But the adjustment and alignment is identical to the 4 facet drill. The difference is only the top angle adjustment. Here use **180°-185°** (see picture below).

The sharpening procedure is identical. For cutters with more than two cutting edges use the magnetic depth stop, listed under special accessoires. For cutters with odd. cutting edges (e. g. 3-cutters) each cutting edge has to be adjust separately. Having cutters with even numbers of cutting edges, the opposite is cutting edges can be ground by reversing.

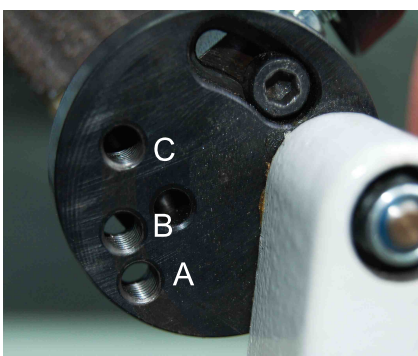

A: Locking for main cutting edge

B: Locking for free sharpening

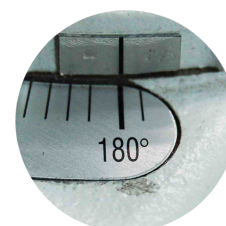

Prism rest
180° - 185°

17. STEP DRILLS

Grinding wheel: Depending on the drill, use corundum or diamond wheel.

ATTENTION! Only step drills with two steps can be sharpened!



Grinding of the 1. Stufe (tip): Alignment and sharpening as for right hand drills (see picture below).

The second step is adjusted in length and side direction as twist drills.
The tip angle is adjusted on the prism support.
Clearance angle as per your request.

Grind the second step over the right side of the grinding wheel.

Alignment of the tip



Alignment of the step



17.1 CARBIDE DRILLS

Use diamond wheel! (option)
 Change of the grinding wheel, see page 29.

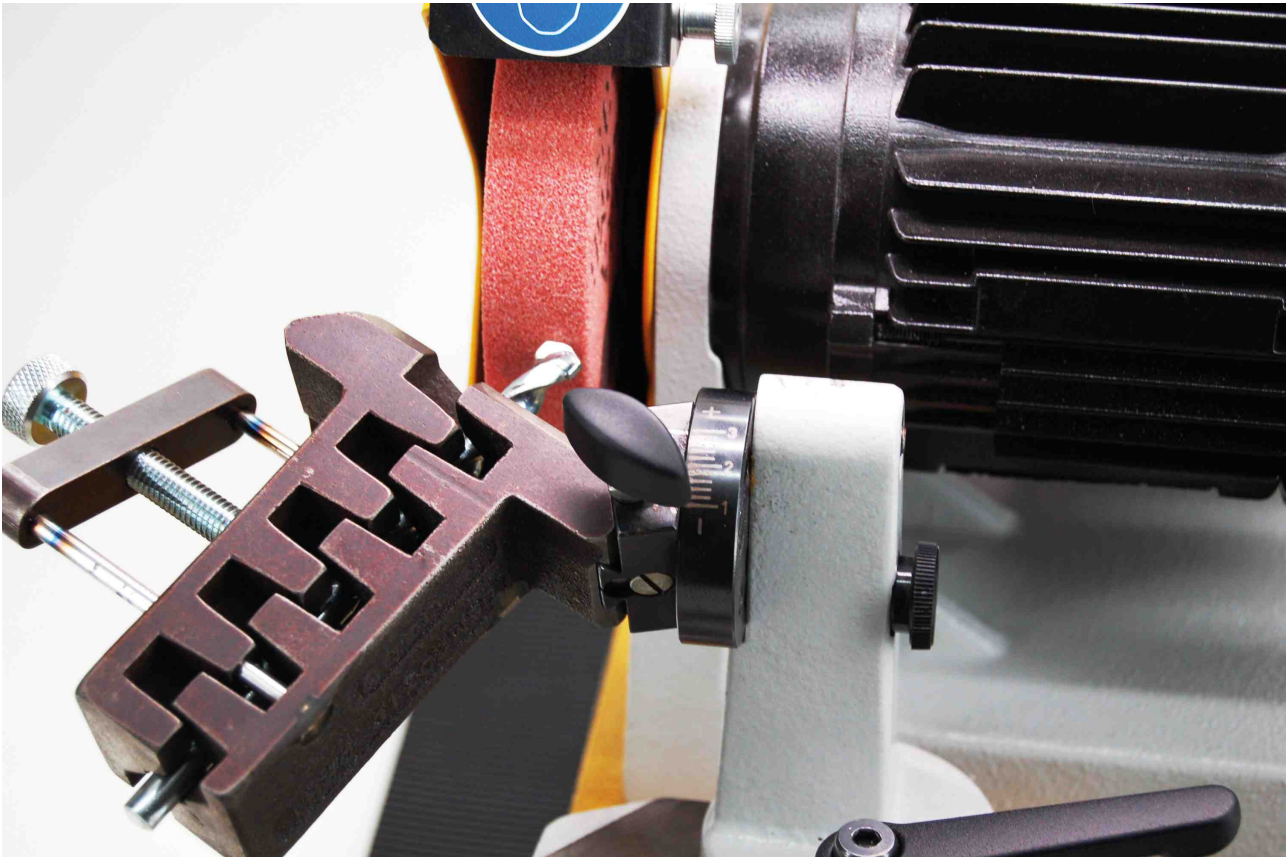

Grinding of carbide drills depending on shape of cutting edge use the 4 facet shape or twist drills. The sharpening of stone drills with 4 facet shape is same as described on page 19.

The sharpening of stone drills with standard twist drill shape is same as described for right hand drills (see page 15).



4 facet shape

Align main cutting edge straight to line



Twist drill shape

Align main cutting edge between both graduation marks

17.2 SHEET METAL DRILLS (with center tip)

Grinding wheel: Corundum, dress the right side of the wheel with an angle of **approx. 45°**.

Use the grinding wheel dresser to dress the requested shape.



Adjustment of drill



Prism rest

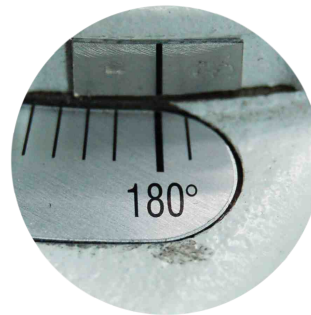

Adjustment of the drill in the prism:

- Adjust the main cutting edge parallel to both graduation line on the prism (see pic.)
- Project the drill around **35 - 40 mm** outside the prism

Adjustment of the machine:

- Top angle: 180° left
- Clearance angle: to your requirement

Grinding operation:

By carefully feeding the prism towards the wheel and meantime swivelling the prism, grind the first side of the cutting edge, then move with the motor feed to the centre tip of the drill bit and grind over the tip using the **45°** dressed side of the grinding wheel.

Note the No. on the scale of the prism feed and move back, remove the prism of the prism support, reverse, fix again in the support and grind the second cutting edges to the same graduation No. Now the second side of the tip is ground centrally.

The tip thinning is identical as for twist drills (see page 18).

17.3 GRINDING OF WOOD DRILLS

Grinding wheel: depending of the material the drill is made of, thin corundum or thin diamond wheel.



Adjustment of the drill in the prism:

- Main cutting edge parallel to both graduation lines
- project the drill: approx. 35 - 40 mm outside the prism

Adjustment on the machine:

- Tip angle: 180° left
- Clearance angle: to your requirement

Grinding of the drill:

By carefully feeding the prism towards the wheel and meantime swivelling the prism, grind the first side cutting edge, then move with the motor feed to the centre tip of the drill bit and grind over the tip using the **45°** dressed side of the grinding wheel.

Note the No. on the scale of the prism feed and move back, remove the prism of the prism support, reverse, fix again in the support and grind the second cutting edge to the same graduation No. Now the second side of the tip is ground centrally. Move with the motor feed to the left and grind the outer cutter with the dressed side of the grinding wheel.

The second outer cutter grind with the same setting.
The tip thinning is identical as for twist drills (see page 18).

17.4 GRINDING OF FORSTNER DRILLS

ATTENTION! Only the open types can be ground!

Grinding wheel: depending on the material the drill is made of, use a thin corundum or thin diamond wheel.

Adjustment of the drill in the prism:

The outer and main cutting edges are placed directly on the grinding wheel.

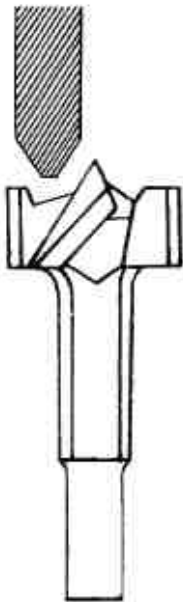

Adjustments on the machine:

- Tip angle: 180° left
- Clearance angle: to your requirement
- Turning mechanism: fix in hole A

Grinding of the main cutting edges:

- Align the main cutting edge to the grinding wheel, so that the outer edge cannot be hurt by the grinding wheel.
- Grind the first main cutting edge from the inside to the outside
- Reverse the prism and grind the second main cutting edge from the outside to the inside

17.5 GRINDING OF THE OUTER CUTTING EDGES

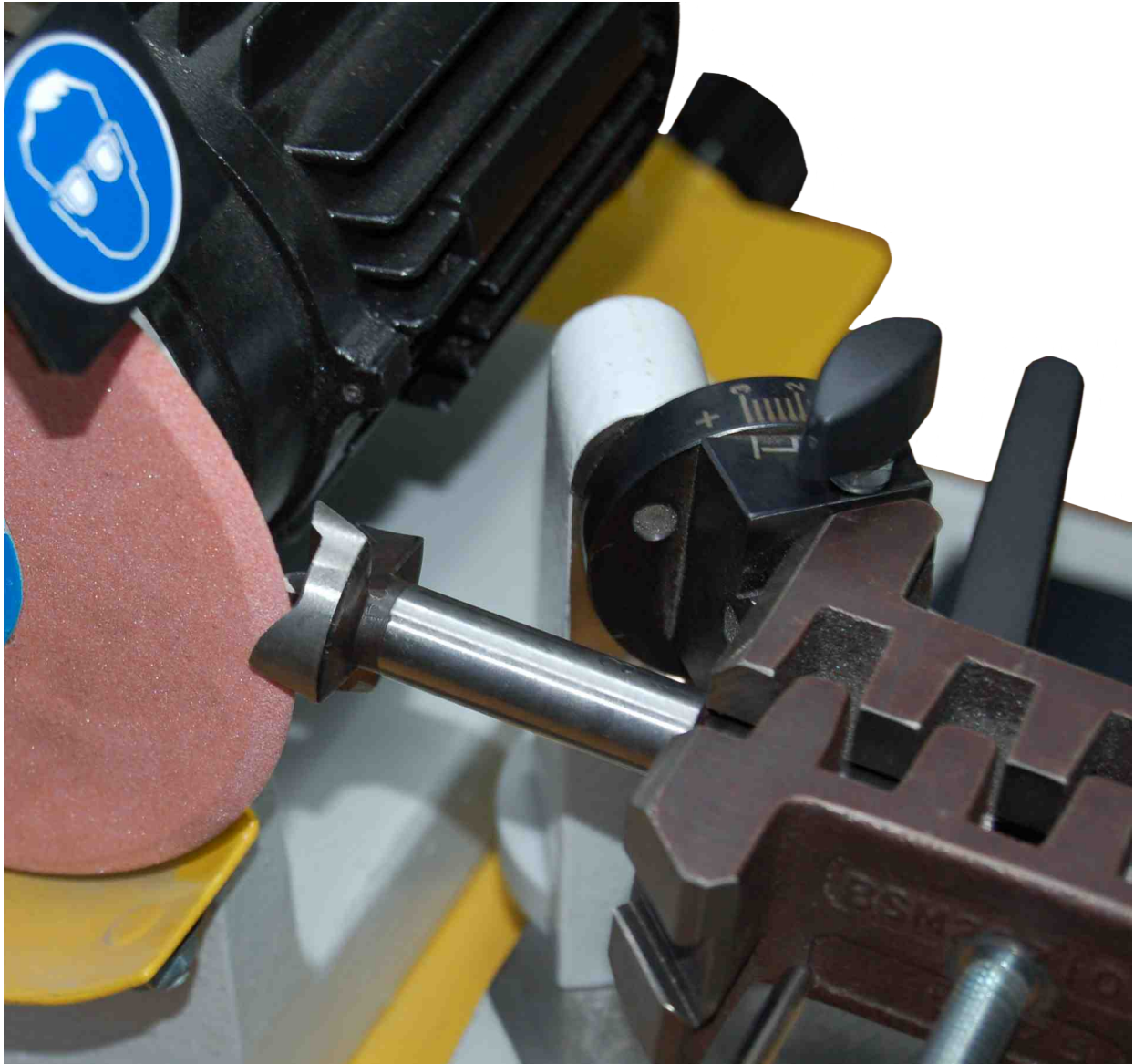

Adjustment on the machine:

- Tip angle: 180° left
- Clearance angle: to your requirement

Align outer cutters to the grinding wheel and grind by reversing.

18. COUNTERSINK SHARPENING DEVICE SVR 20

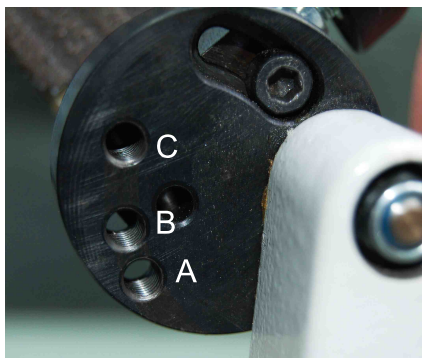
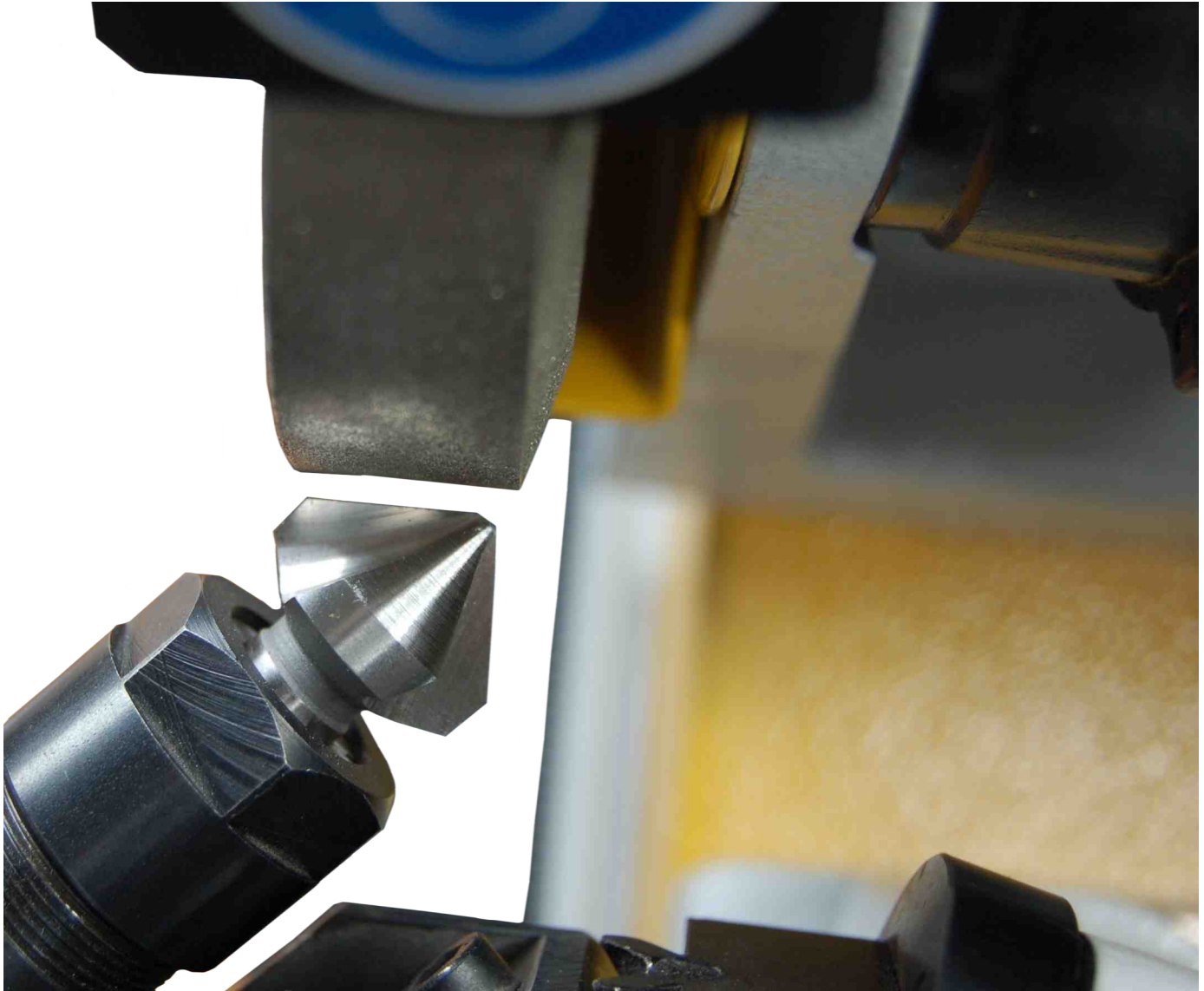

Fix in hole A

19. COUNTERSINK SHARPENING DEVICE SVR 20

For sharpening countersinks with the BSM 20 / SZ, this special accessory type SVR 20 is required. Arrest the turning mechanism on the BSM 20 drill sharpening machine in hole **A** (see picture on page 26). Fix the stepless clearance angle adjustment on the third graduation mark from above (see picture). The prism rest fix at **90°** (see draw).

Place your countersink inside the collets of the SVR 20 and align one cutting edge parallel to the line on the SVR 20, below the collets nut (see also drawing E). With the screw **I** and **J** (see the drawing on the right) you can adjust the distance between the SVR 20 and the grinding wheel. For bigger countersinks the SVR is positioned backwards and can only fixed with one screw on the adaptor plate. Slide the SVR 20 on the turning mechanism to the stop dog and fix with the clamping screw.

By turning the hand wheel of the SVR 20 clockwise and carefully moving forward with the prism feed on the BSM 20 you can sharpen the flutes of your countersink.

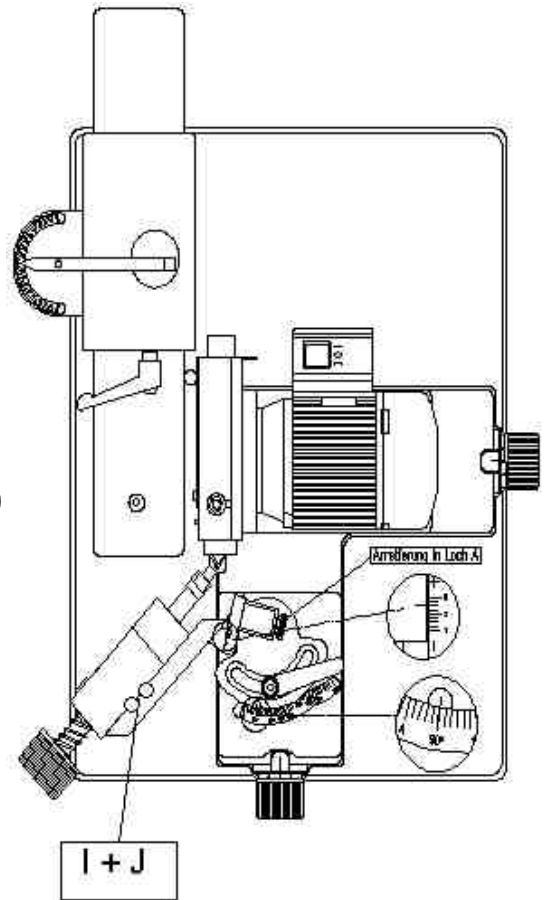

It is absolutely recommended grinding with a clean and parallel dressed grinding wheel.

For one-flute countersinks you have to mount the special cam (Art No. 10605) for adjusting see drawing **F**.

ATTENTION! When you align the tip of countersink parallel to the graduation line on the SVR 20, take care that the bigger hole is on this side.

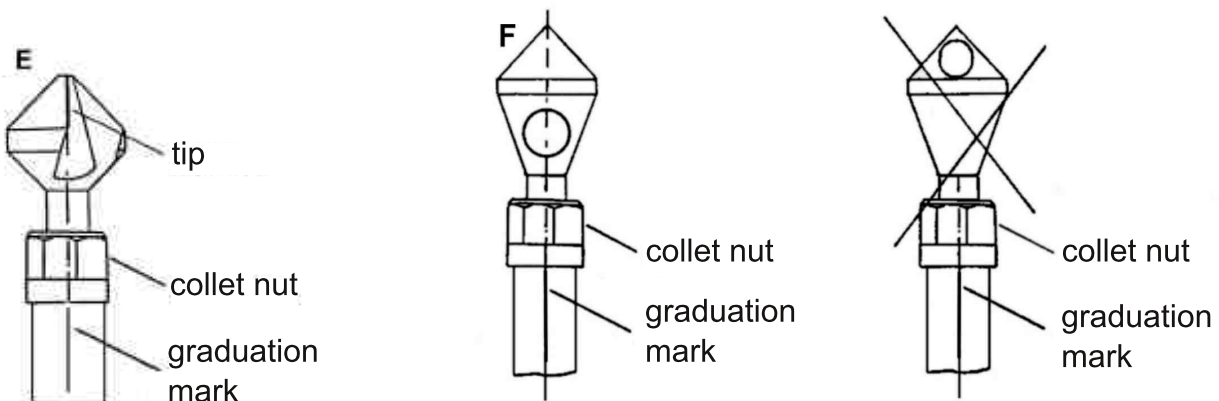

20. MOUNTING AND DRESSING OF THE GRINDING WHEEL BEFORE THE FIRST START

After you have moved the machine to its final place take the grinding wheel and make a sound and optical check.

Then mount the wheel on the support.



Grinding support wheel



Mounted wheel with support

Now slip the mounted wheel with support in the motor shaft (see page 31).

After you have checked the correct position of the wheel and the grinding wheel protection cover you have to dress the wheel (see page 30).

Only when you follow these advises, a safe and correct working with the machine is granted.

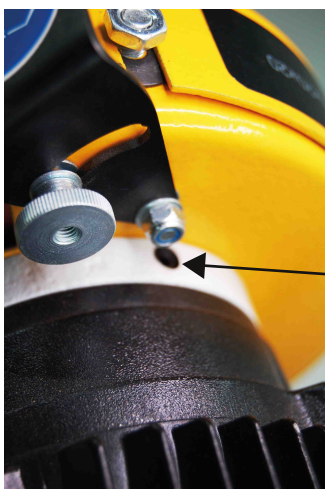

PROTECTION ADJUSTMENT

By opening the threaded pin you have the option to adjust the grinding wheel cover. After correct adjustment please tighten the threaded pin again.

Threaded pin

21. CHANGE THE GRINDING WHEEL

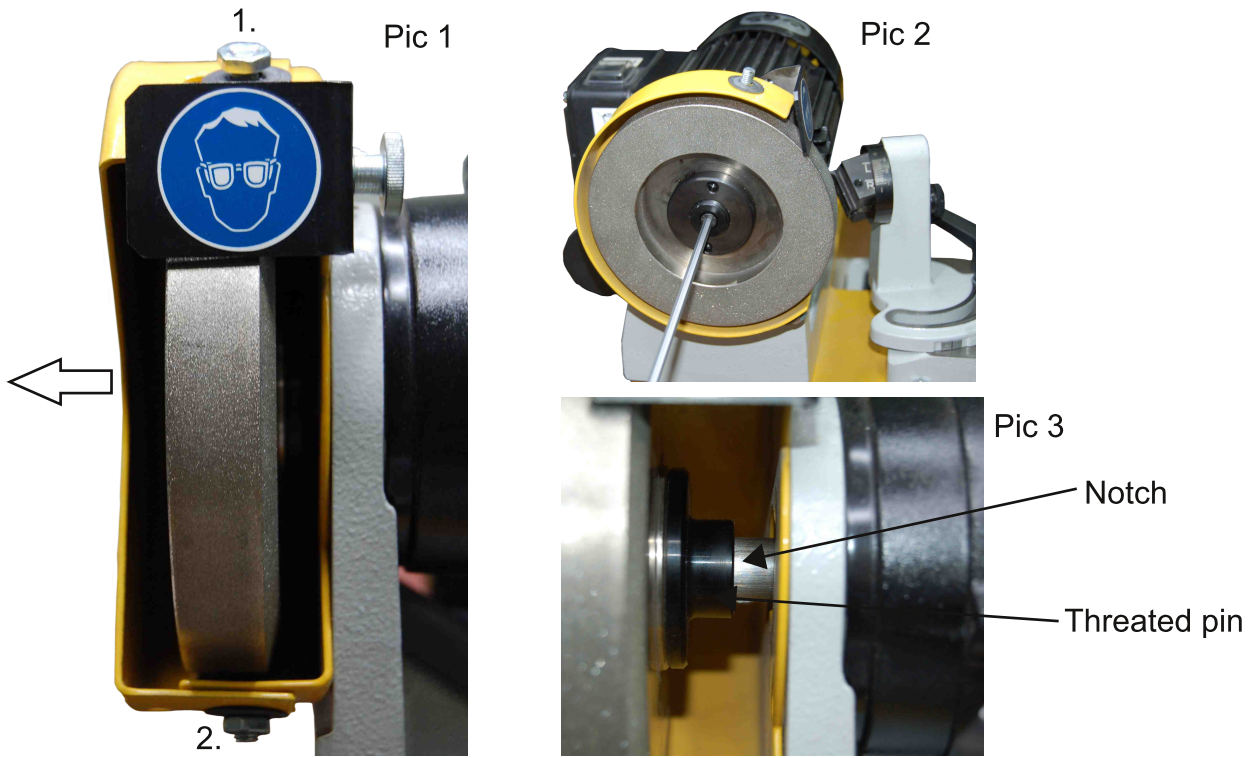

Before changing the grinding wheel, disconnect from electric net.

Loosen both hat cap screws (1 + 2) with a 10 mm engineers wrench and remove the grinding wheel cover to the left (picture 1). Now loosen the screw in the middle of the wheel support with the hexagon socket wrench SW 4,0 (comes with the machine) (picture 2). Now you can tear the grinding wheel with support with the included key and change the grinding wheel.

By slinding the support on the motor shaft, pay attention that the threaded pin of the support is in the notch of the motor shaft (picture 3). Now fix the haxagon socket screw SW 4,0 and make sure that the cover is mounted correctly.

Never use the corundum cup wheel for drill grinding.

The grinding wheels habe to cmply with norms **EN 12413** or **EN 13236**. After the wheel change, start a text run of minimum one minute.



The BSM 20 is not allowed to be operated without a correctly mounted grinding wheel cover.

22. DRESSING OF THE GRINDING WHEEL

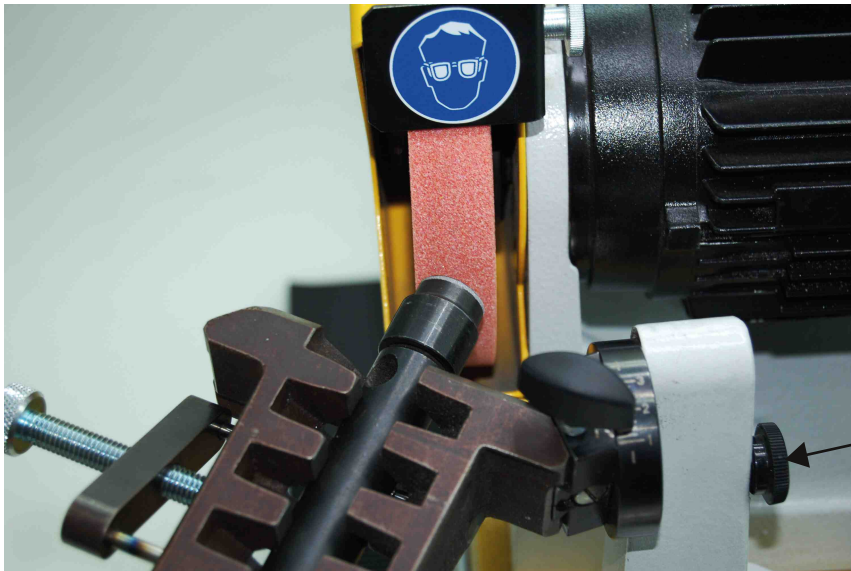

Fix clamping screw in hole A

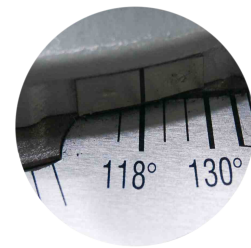

Place the dresser Part No, 10908 in the prism, in order the rotating front part can still be turned.

Fix the clearance angle to No. 2 and set the angle on the support rest to **118°**.
Now fix the clamping screw in hole **A** (see picture ahead).

Now carefully move the prism feed toward the wheel so the rotating diamond part starts turning. Now feed **max. 1-2 part lines**. By moving the motor feed, you can now dress the wheel.

OPERATING INSTRUCTION FOR TOOL SHARPENING CENTER SZ



1. DESCRIPTION OF PARTS SZ

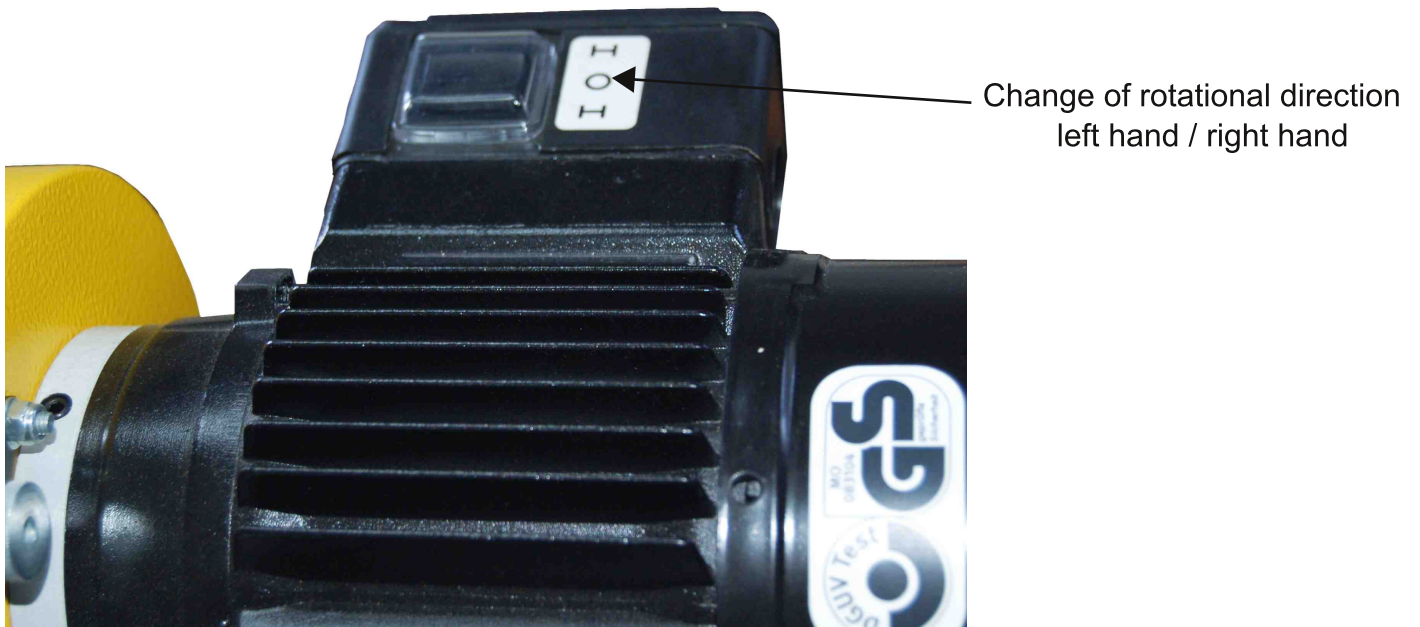
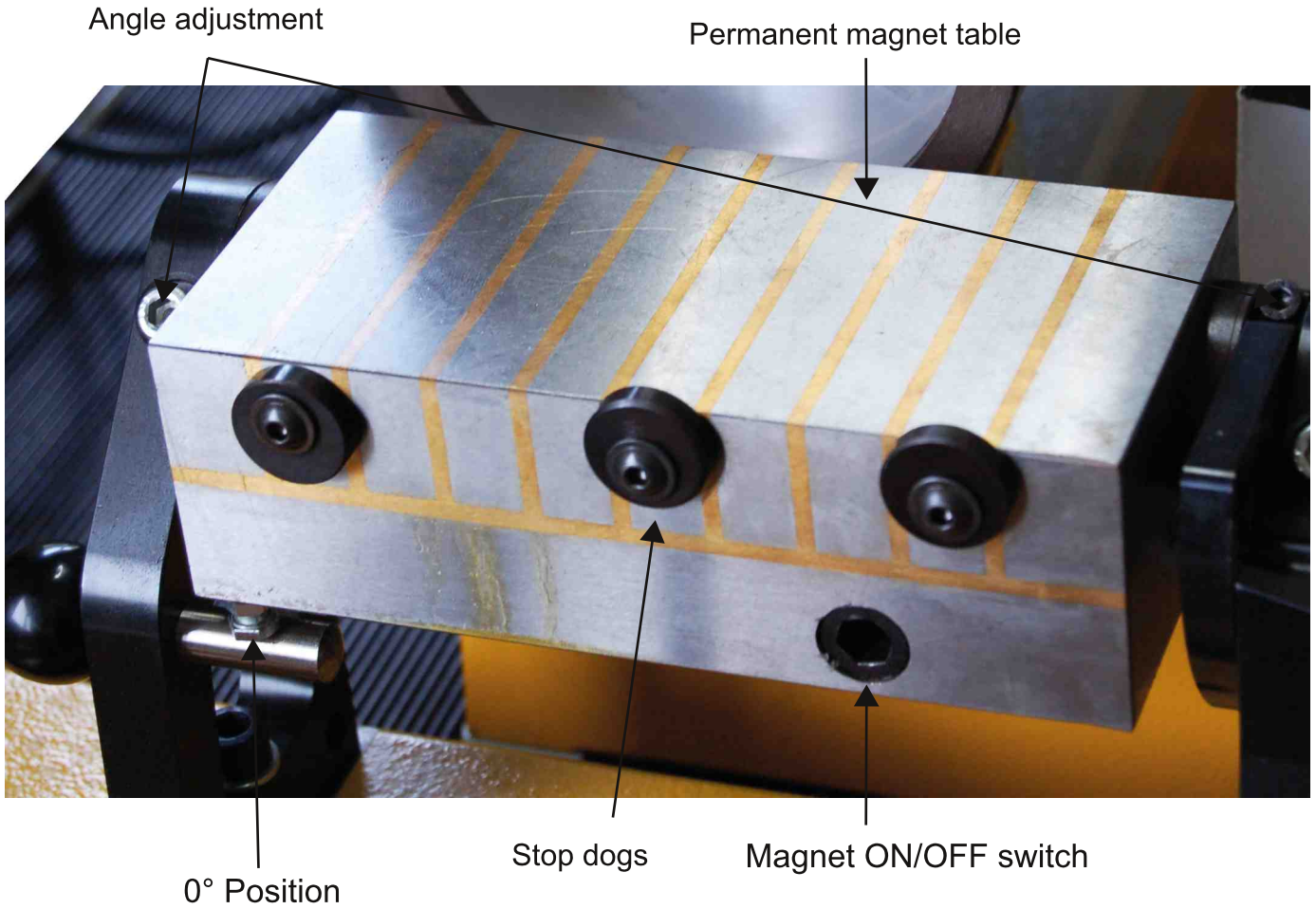

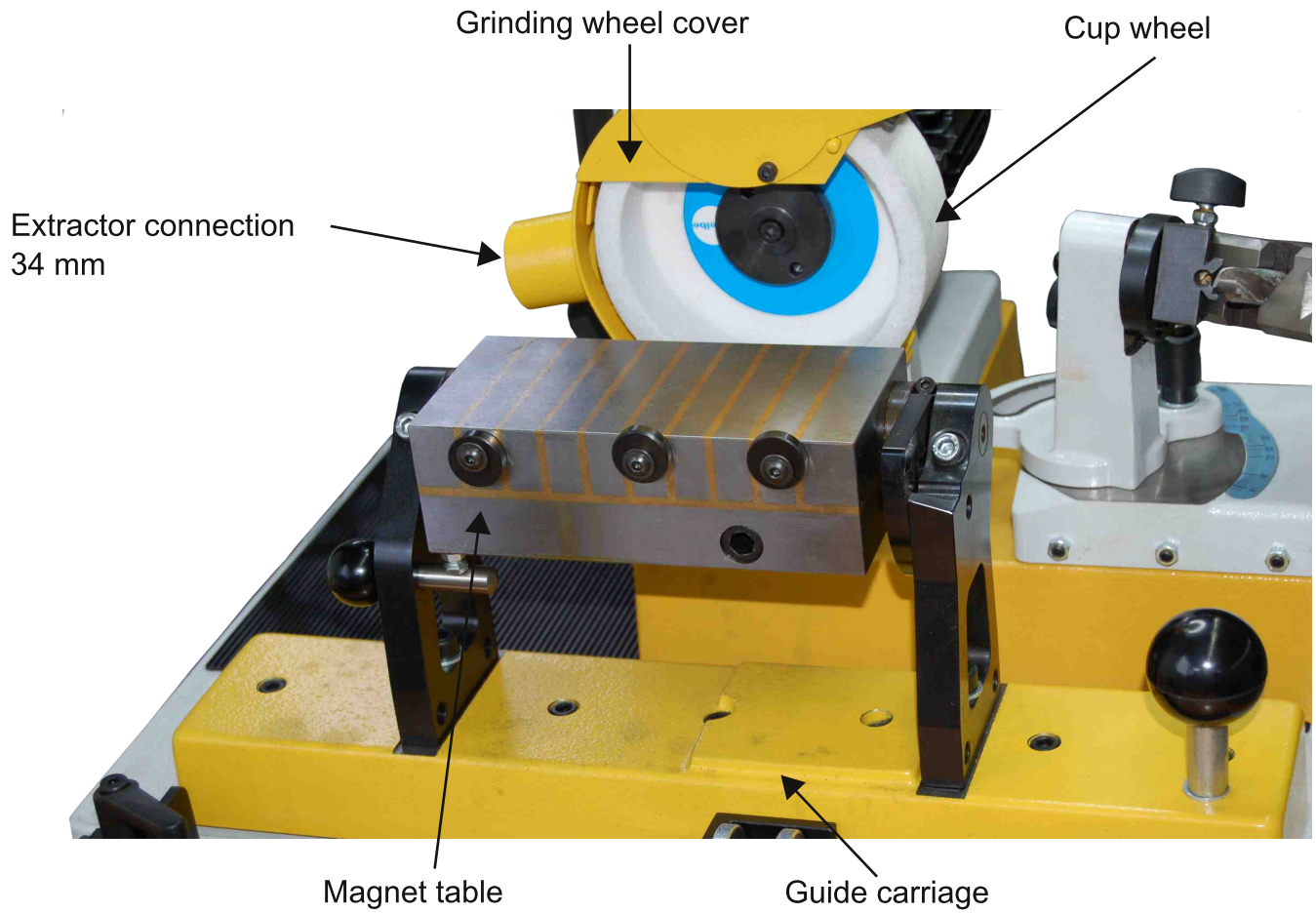

By opening the hexagon screws, the magnet table can be adjusted from -10° to 90° .

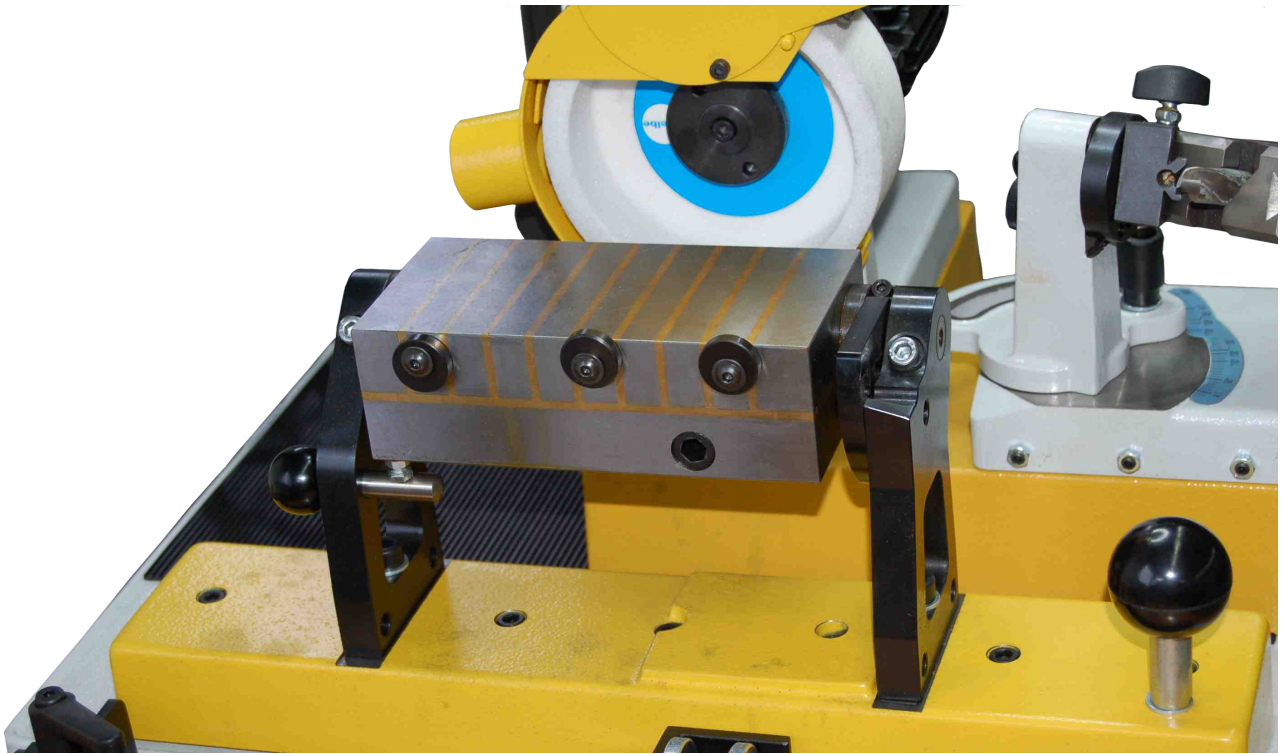

With the stop dogs on the back of the magnet, you can align and adjust the corresponding angles of your tools by use of a angled blade.

2. DRESSING OF THE CORUNDUM CUP WHEEL

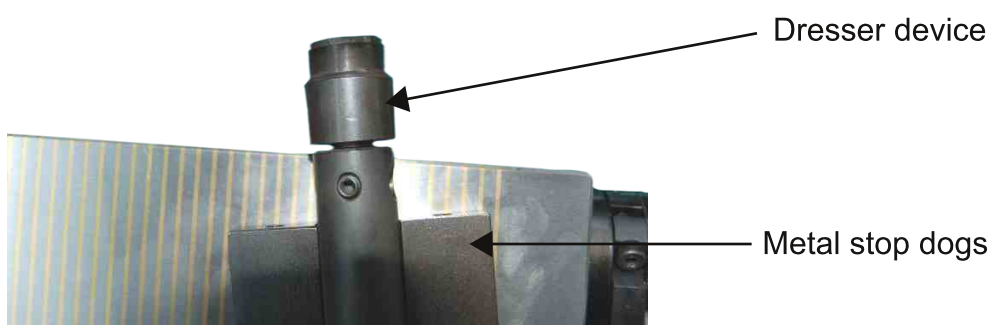

- Place the magnet with the flat side on the permanent magnet table (see picture).
- Place the dresser unit with a little angle to the grinding wheel on the magnetic table.
- Place 2 metal stops on the left and right side of the dresser unit. This grants a soft smooth dressing of grinding wheel.
- Adjust the magnetic table to an angle of 2° .
- The feeding should be max. 2-3 graduation lines on the motor feed.
- By moving of the guiding carriage, the wheel is dressed.
- When dressing the grinding wheel, please connect a dust exhaust (e. g. industrial vacuum).

3. OPERATION OF THE SZ



Holder for very small planer knives



Holder for mortise chisels

With the sharpening center SZ, different tools can be sharpened. It is important that depending on the tool, the correct grinding wheel is mounted (e. g. diamond cup wheel).

By fixing the tools, please pay attention that the magnet holds tight the tools. If not use the universal tool holder.

The relevant grinding angles you can adjust with the operation parts as shown. By moving the slide and feeding with the motor feed, the adjust cutting edges of each tool can be sharpened.

4. MAINTENANCE

CLEANING AND GREASING

The BSM 20 / SZ should be cleaned from grinding dust, using a soft brush, once a weeks. Persistent dirt, please clean with a usual in trade machine cleaner. After cleaning, please grease al movable parts with some drops of machine oil. To prevent corrosion of the blank parts, also grease with little oil and rug with a soft rag. The prism- and motor slides should be greased every three month, using the lubrication nipples. Please use special sliding- or roller bearing grease.

REPAIRS

All parts listed in the spare part list, can be replaced by the user. Repairs of assembly groups, as reversing prism or the blase plate with guide and spindle, can pny be repaired in our company. Reason is, these parts are mainly responsible for the precission of the BSM 20 / SZ.

WEAR PARTS BSM 20 / SZ

Item. No.	Description
10896	Corundum cup wheel SZ grit 60 (125x40x20)
10897	Corundum cup wheel SZ grit 80 (125x40x20)
10898	Corundum cup wheel SZ grit 100 (125x40x20)
10909	Spare diamond dresser head
10910	Support for diamond dresser
10890	Corundum grinding wheel BSM 20 grit 80 (125x20x20)
10891	Corundum grinding wheel BSM 20 grit 180 fine
10895	Corundum grinding wheel BSM 20 grit 60
10893	Corundum grinding wheel BSM 20 grit 100 (125x5x20)
11103	Corundum grinding wheel BSM 20 grit 100(125x10x20)
17073	CBN grinding wheel BSM 20 ø 125 mm B126/3 (width 20 mm)
16490	CBN grinding wheel BSM 20 ø 125 mm B76/3 (width 20 mm, standard)
17556	CBN grinding wheel BSM 20 ø 125 mm B46/3 (width 20 mm)
15422	Grinding wheel support

WARRANTY

The warranty is **12 months** from date of shipment and refers to a **one shift work** under condition of a appropriate use of the machine.

The guarantee includes the costs of replacing of defect parts and assembly groups, including the required working time.

Excluded from any gurantee are:

- Wear parts
- Transport damage
- An improper use
- Damage by use of force
- Damages and consequential damages caused by breach of the duty taking care of the user

In case of a warranty claim, we ask you to inform us about the serial No. of the machine.

Returns have to be authorized by us, before shipment.

We reserve the right to charge you with the transportation cost, if the return was not authorized.

Spare parts or replacement parts are transferred abolutely in our ownership.

DISPOSAL OF THE MACHINE INSIDE EU

When sending back the machine to us (transport charges prepaid), the company Kaindl-Schleiftechnik Reiling GmbH grants for the competent disposal as per the currently in force guidelines of the Europeen waste equipment regulations.

5. SPARE PART LIST BSM 20

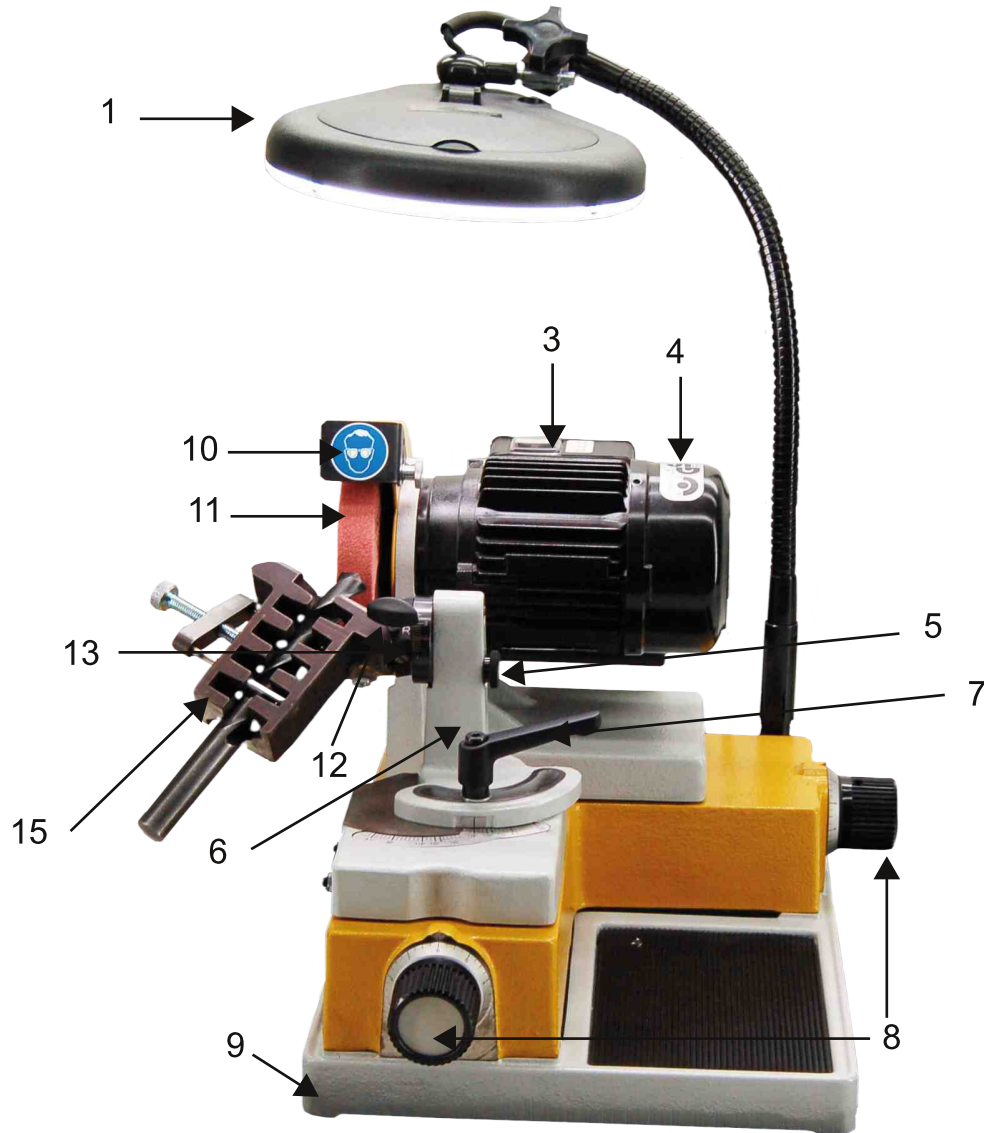

1. Art. Nr. 18070 Precision lens with LED light BSM 20
2. Art. Nr. 10923 Motor 230 V / 50 Hz bulk
3. Art. Nr. 11013 Motor switch complete with box
4. Art. Nr. 10567 Fan wheel cover
5. Art. Nr. 10549 Fixation screw M6
6. Art. Nr. 11235 Prism rest
7. Art. Nr. 10959 Clamping lever M8 BSM 20
8. Art. Nr. 10915 Turning knob with scale for prism and motor feed
9. Art. Nr. 12335 Base plate BSM 20
10. Art. Nr. 11261 Spark protection flap 42 mm adjustable BSM 20
11. Art. Nr. 10914 Grinding wheel cover 3 parts. BSM 20
12. Art. Nr. 11399 Wing screw for prism fixation M5
13. Art. Nr. 11095 Clearance angle adjustment BSM 20
14. Art. Nr. 11006 Prism support BSM 20 with wing screw
15. Art. Nr. 10905 Prism 1-20 mm BSM 20

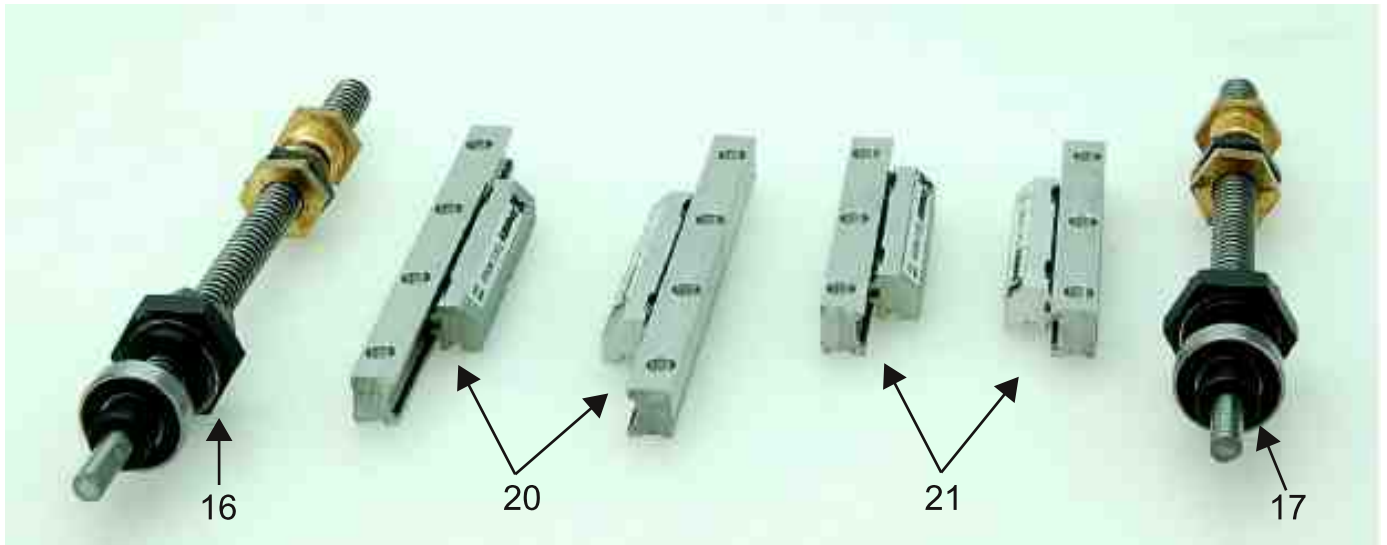

- 16. Art. Nr. 10924 Spindle system complete for motor feed, L = 37 mm
- 17. Art. Nr. 12336 Spindle system complete for prism feed, L = 217 mm
- 18. Art. Nr. 12340 Guidance set (old version) for motor feed
- 19. Art. Nr. 12341 Guidance set (old version) for prism feed
- 20. Art. Nr. 12343 Guidance set (new version) for motor feed
- 21. Art. Nr. 12342 Guidance set (new version) for prism feed

When placing an order, please tell your No. of machine and year of construction!

5. SPARE PART LIST SZ

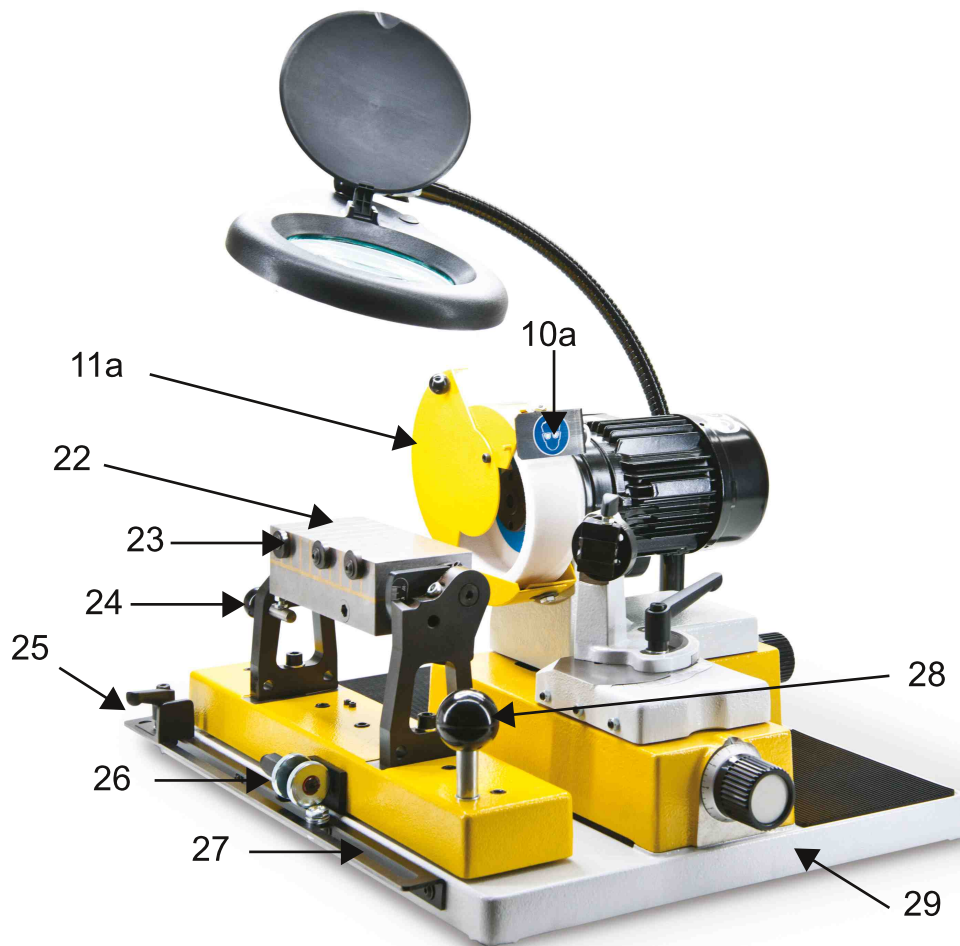

- 10a. Art. Nr. 12347 Spark guard shutter adjustable SZ
- 11a. Art. Nr. 11332 Grinding wheel protection complete 3 piece for SZ
- 22. Art. Nr. 11073 Permanent magnet
- 23. Art. Nr. Stop dogs
- 24. Art. Nr. 12353 Support pin for 0°
- 25. Art. Nr. 12349 Stop dog complete with clamping lever
- 26. Art. Nr. 12350 Hydraulic final dampers
- 27. Art. Nr. 12351 End stop rail SZ
- 28. Art. Nr. 12352 Hand lever SZ
- 29. Art. Nr. 12355 Base plate SZ
- 30. Art. Nr. 12357 Precision guidance set complete with guiding carriage

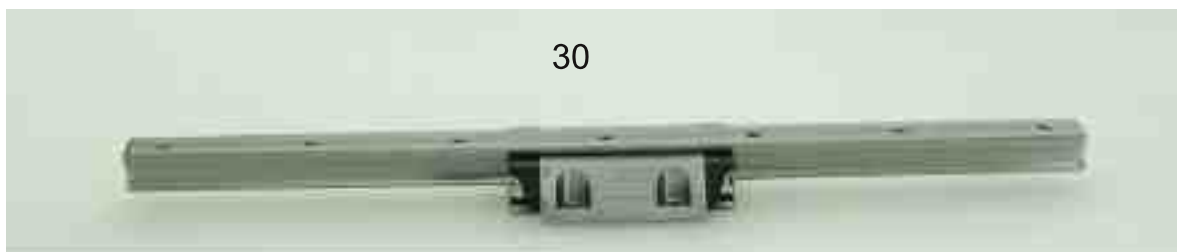

30